



REGIONE PIEMONTE (ITALY)

<http://www.regione.piemonte.it/>

Technologies
from Space
Exploration

HEALTHCARE

Title: **MARISSA**

Authors: Sergio Chiesa; Giuseppe Tartara

Author Affiliations: S.P.A.I.C.srl: Provincia di Torino

Participants:

MARISSA study sees the collaboration of NT-Planet sas, CAB Electra snc and IEIIT-CNR, with the support of Tele-Hospital srl



MARISSA

Mobilità
Autonomia
Robots
Innovativi
Servizio
Supporto
Anziani



REGIONE PIEMONTE (ITALY)

<http://www.regione.piemonte.it/>

Technologies
from Space
Exploration

HEALTHCARE

Title: **MARISSA**

Authors: Sergio Chiesa; Giuseppe Tartara
Author Affiliations: S.P.A.I.C.srl: Provincia di Torino

Participants:

MARISSA study sees the collaboration of NT-Planet sas, CAB Electra spc and IEIIT-CNR,
with the support of Tele-Hospital srl

What is MARISSA ?

MARISSA (an English translation of the Acronyms could be: “Mobility and Innovation for Small Mobile Robotic Vehicles for Senior People Monitoring and Care”) **is a concept of a Robotic System capable of assisting Old People, that live alone in their house.**

The System allows :

- That a remote User (Familiar or Social Operator) can **visually monitor the Person** under care at any time
- That he/she can **communicate easily whenever he/she wants** (with view of a “well known face”).
- That the System could also perform **simple tasks, like, for instance, “diary”, “clock” and administering medicines at the right time, with check of the effective consumption.**



REGIONE PIEMONTE (ITALY)

<http://www.regione.piemonte.it/>

Technologies
from Space
Exploration

HEALTHCARE

Title: **MARISSA**

Authors: Sergio Chiesa; Giuseppe Tartara
Author Affiliations: S.P.A.I.C.srl: Provincia di Torino

Participants:

MARISSA study sees the collaboration of NT-Planet sas, CAB Electra snc and IEIIT-CNR, with the support of Tele-Hospital srl

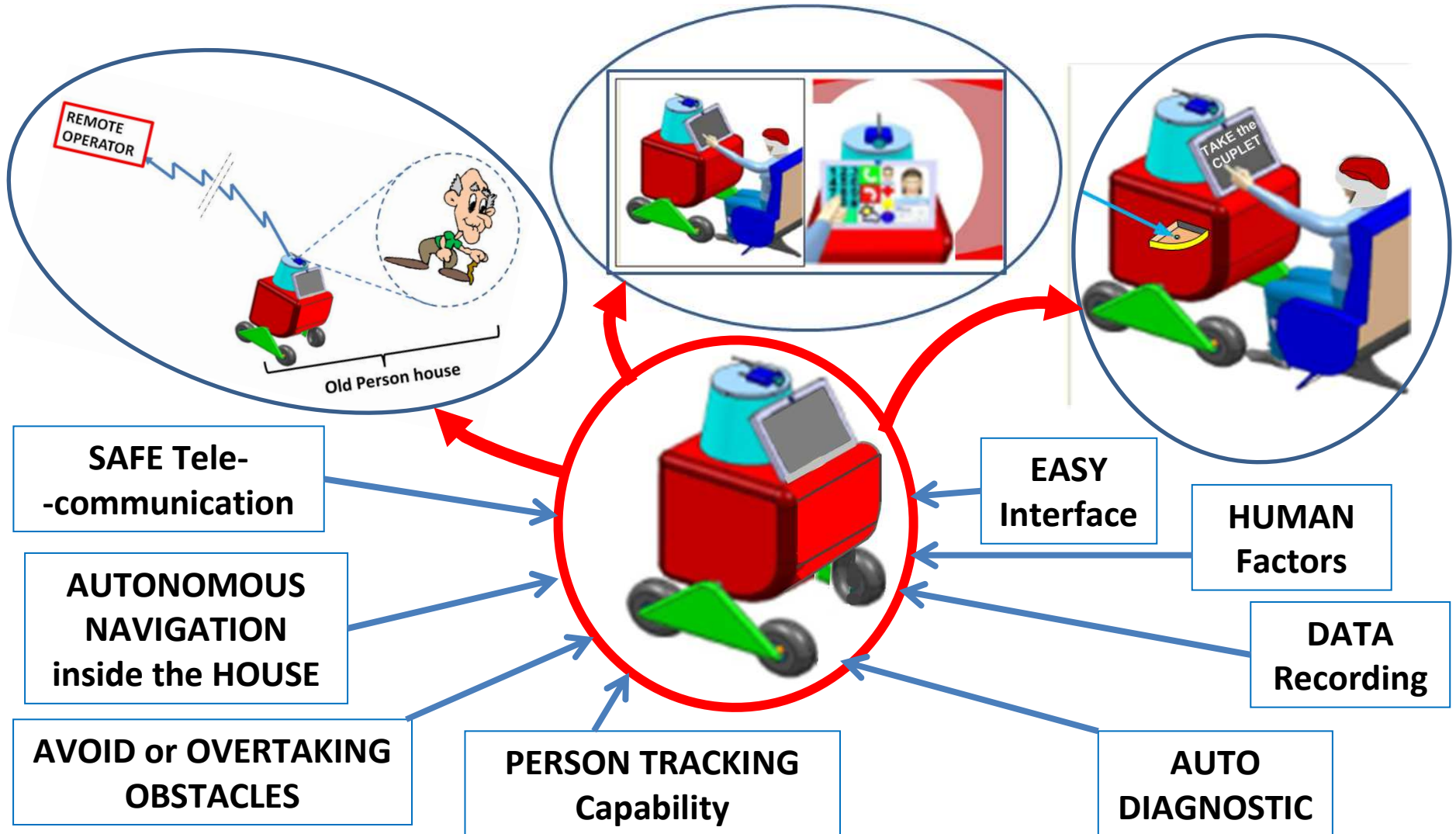



REGIONE PIEMONTE (ITALY)

<http://www.regione.piemonte.it/>

*Technologies
from Space
Exploration*

HEALTHCARE

Title: MARISSA

Authors: Sergio Chiesa; Giuseppe Tartara
Author Affiliations: S.P.A.I.C.srl: Provincia di Torino

Participants:

MARISSA study sees the collaboration of NT-Planet sas, CAB Electra spc and IEIIT-CNR,
with the support of Tele-Hospital srl

Main advantages expected by MARISSA Project:

- a) In case of self sufficient Person, MARISSA will allow a concrete possibility of staying in his/her house, even if alone, with acceptable level of Safety and a good situation of communication with relatives
- b) The cost of MARISSA that offers a h24 service will be extremely competitive with the cost of service of a Person (not a specialized nurse) that works for the same number of hours
- c) A dramatic reduction (thanks to prevention) of cost for National Health System (emergency calls and consequent Hospitalization)
- d) The psychological advantage for many Elderly People is the possibility of keeping on staying in their houses



REGIONE PIEMONTE (ITALY)

<http://www.regione.piemonte.it/>

Technologies
from Space
Exploration

HEALTHCARE

Title: **MARISSA**

Authors: Sergio Chiesa; Giuseppe Tartara
Author Affiliations: S.P.A.I.C.srl: Provincia di Torino

Participants:

MARISSA study sees the collaboration of NT-Planet sas, CAB Electra snc and IEIIT-CNR, with the support of Tele-Hospital srl



HERITAGE

Studi, Prototipi, Attività per Innovazione e Competitività (S.P.A.I.C.)srl is an academic spin-off of POLITECNICO di TORINO, born in January 2007 in Torino

Mini Rover
for indoor
monitoring



ROVER "X"



Technological Demonstrator derived from early studies on "X" Prize Rover, devoted to mobility studies and to investigate FUEL CELL employment for powersupply.

D. R. E. A. M.

"Dimostratore Rover Elettrico per Avanzata Mobilità"

To investigate the application of "SWITCHED RELUCTANCE" MOTOR for space rovers.



VIBRISSA

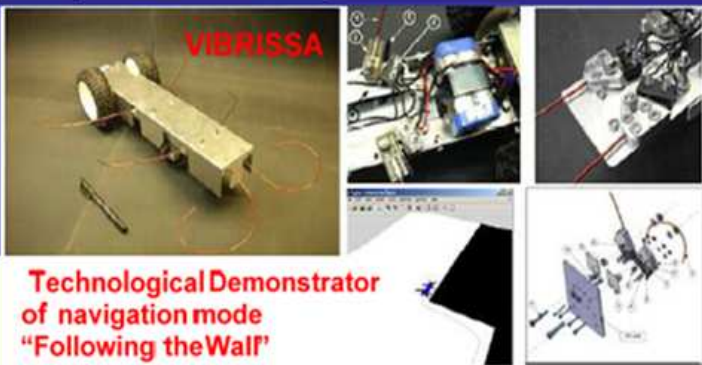

Technological Demonstrator of navigation mode "Following the Wall"

S.P.A.I.C.srl Products in Space Exploration activity

STEPS Program elastic wheel for lunar rover



AMALIA lunar rover deployment System preliminary BREADBOARD

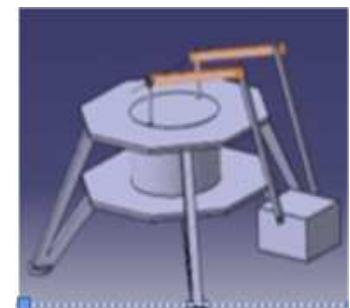

Title: **MARISSA**

Authors: Sergio Chiesa; Giuseppe Tartara
Author Affiliations: S.P.A.I.C.srl: Provincia di Torino

Participants:

MARISSA study sees the collaboration of NT-Planet sas, CAB Electra spc and IEIIT-CNR, with the support of Tele-Hospital srl

SPACE KNOWN-HOW USEFUL FOR MARISSA

SPACE ENGINEERING KNOWN-HOW

Efficient and rational set-up of very different and conflictual requirements in order to optimize project definition

SAFETY
RELIABILITY
MANTAINABILITY

Human factors

Communication

Mobility of the Robot {
GNC
Obstacle avoidance
Obstacle overtaking

Sensors,
Motors,
Batteries

Virtual Reality
and Simulation



REGIONE PIEMONTE (ITALY)

<http://www.regione.piemonte.it/>

Technologies
from Space
Exploration

HEALTHCARE

Title: **MARISSA**

Authors: Sergio Chiesa; Giuseppe Tartara
Author Affiliations: S.P.A.I.C.srl: Provincia di Torino

Participants:

MARISSA study sees the collaboration of NT-Planet sas, CAB Electra snc and IEIIT-CNR, with the support of Tele-Hospital srl

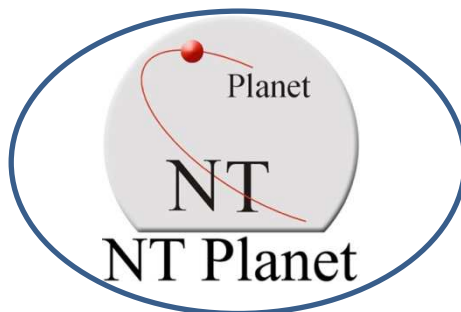
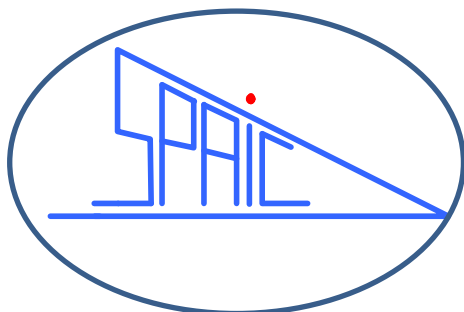

The MARISSA team

S.P.A.I.C. srl

Studi, Prototipi, Attività per
l'Innovazione e la Competitività
corso Einaudi 59
10129 Torino
ITALY

Tel: +39 0117641309

Fax: +39 0117608523

www.spaic-srl.com

sergio.chiesa@spaic-srl.it

NT-Planet s.a.s.

di M. & A. Gennaro
Via Fattori 20
10141 Torino
ITALY

Tel: +39.011.331399

www.nt-planet.com

nt-planet@nt-planet.com

Cab Electra S.r.l.

Produzione Apparecchiature
Elettroniche ed Elettromeccaniche

Strada del Cascinotto,
139/18 10156 Torino
ITALY

Tel. +39 011 27 31 286

Fax +39 011 27 34 229

www.cabelectrasrl.com

info@cabelectrasrl.com

IEIIT

(Institute of Electronics,
Computer and
Telecommunication Engineering)
[National Research Council of
Italy](http://www.ieiit.cnr.it)

c/o Politecnico di Torino, corso
Duca degli Abruzzi, 24 - 10129,
Torino, Italy.

Phone: +39 011 564 5400 -

Fax: +39 011 564 5429

www.ieiit.cnr.it/about.php



REGIONE PIEMONTE (ITALY)

<http://www.regione.piemonte.it/>

Technologies
from Space
Exploration

HEALTHCARE

Title: **MARISSA**

Authors: Sergio Chiesa; Giuseppe Tartara
Author Affiliations: S.P.A.I.C.srl: Provincia di Torino

Participants:

MARISSA study sees the collaboration of NT-Planet sas, CAB Electra spc and IEIIT-CNR, with the support of Tele-Hospital srl

MARISSA Status

- ***MARISSA has been conceived by S.P.A.I.C. srl that has proposed it, together with other Partners (two SME and a Research Institute), as a Project to be developed with financial Support of Italian Ministry of Research (MIUR).***
- ***The project has been rated very high even if the financial contribute of Ministry is not available yet.***
- ***In the meanwhile the MARISSA Team has continued to study the Concept.***
- ***The experience in the meantime acquired by S.P.A.I.C.srl in Space Exploration context is CONTINUOUSLY transferred to the development of MARISSA and this will be certainly relevant for the future evolution.***



REGIONE
PIEMONTE

REGIONE PIEMONTE (ITALY)

<http://www.regione.piemonte.it/>

*Technologies
from Space
Exploration*

HEALTHCARE

Title: MARISSA

Authors: Sergio Chiesa; Giuseppe Tartara
Author Affiliations: S.P.A.I.C.srl: Provincia di Torino

Participants:

MARISSA study sees the collaboration of NT-Planet sas, CAB Electra spc and IEIIT-CNR,
with the support of Tele-Hospital srl

*Thank you for
your attention!*